Standard media preparators

AE-MP Series

Technical information





Index

General specifications	3	Strategies to increase productivity	22
Five processes streamlined in one solution	3	Dispensing options.....	22
Automation of culture media preparation	4	Special versions with increased heating capacity.....	23
Benefits of AE-MP Series media preparators	5	Special versions for culture media formulas of high-density.....	23
Model sizes and weights	6	Special dispensing lines adapted for use in multiple workstations.....	23
Understanding the operation of standard media preparators	7	Integrated chiller for faster cooling.....	23
Phases of a sterilization cycle.....	7	Use of self-cleaning functions.....	23
Preparation.....	8	Rotational use of multiple media preparators.....	23
Dispensing.....	9	Scheduled startup.....	23
Automatic cleaning of dispensing lines.....	11	Accessories	24
High-performance sterilizations	13	General.....	24
Steam source.....	13	Dispensing.....	25
Water quality compatibility.....	13	Data logging.....	27
Sterilization with F ₀ regulation.....	14	Qualification.....	28
Pressure control.....	16	Customization of accessories and tailored solutions.....	28
Temperature control.....	16	Customer support and 360° comprehensive consultancy ...29	
Fast cooling.....	17	Before the installation.....	29
Programs with multiple ramps.....	18	During the installation.....	29
Construction quality	19	After the installation.....	29
Sterilization chamber.....	19	Installation, validation, startup and maintenance	29
Gasket and door.....	19	Installation.....	29
Components.....	19	Qualification.....	29
Assembly of the media preparator.....	19	Guided startup.....	30
Controller and monitoring system	20	Preventive maintenance.....	30
Adjustable parameters.....	20	Standard maintenance.....	31
Cycle safeguards.....	20	Stock of emergency components.....	31
Calibration.....	20	Maintenance contract.....	31
Updates.....	20	After-sales services.....	31
Data management	21	Technical data	32
Printer.....	21	Specifications.....	32
Automatic USB backup.....	21	Safety.....	33
SWMP Software.....	21	Certifications.....	33
		General features.....	33
		Annexes	34
		Electrical connection.....	34
		Technical drawings.....	36



Standard media preparators

General specifications

Our standard media preparators from the AE-MP Series have been created to streamline the operational workflow of culture media preparation in microbiology and biotechnology laboratories. They streamline the entire process, reducing total time and workload, while efficiently producing large volumes of sterile culture media. This is achieved through a powerful heating system and a fast cooling system that is activated at the end of the sterilization process.

These media preparators are used in a wide variety of applications such as the preparation of agar, specific media for plant tissue culture, lysogeny broth, buffer solutions and high-density enriched media for fungal cultures. They are essential across various sectors, such as plant tissue labs, plant stem cell culture, microbiology, and clinical analysis laboratories.



Five processes streamlined in one solution

Our standard media preparators are a major advancement in culture media preparation, offering a sharp contrast to traditional methods that rely on standard autoclaves. These media preparators combine five processes within a single piece of equipment:

1. Preparation

The preparation phase occurs within the inner vessel, situated inside the sterilization chamber of the media preparator. This process is simple and requires minimal human intervention. Purified water, freeze-dried culture medium, and nutrients are added in precise amounts. Mixing is fully automated via a magnetic stirring system at the vessel's base, with adjustable speeds between 50rpm and 200rpm, achieving thorough homogenization of the medium. In addition, its powerful Incoloy®825 electric heating elements allow rapid heating of the water in the sterilization chamber, generating saturated steam to heat the inner vessel and sterilize the medium. To further optimize the process, there are models with enhanced heating capacity to further reduce the duration of the heating phase.

2. Sterilization

The sterilization process is conducted with precision and strict regulation. Temperature monitoring is enabled through a flexible probe directly immersed in the preparation, ensuring continuous temperature control. This direct regulation allows for versatile programming of sterilization cycles, either by chamber temperature control or by F_0 regulation, depending on the specific requirements of the medium.

3. Fast cooling

Upon completion of sterilization, a rapid cooling phase is initiated, achieving up to a 90% faster cooling rate compared to natural cooling. The efficiency of this process is due to the water cooling coil incorporated inside the sterilization chamber, completely surrounding the inner vessel. Cold water circulates through the coil, reducing the temperature quickly and enabling safe dispensing of the culture medium within a short period.

4. Dispensing

Dispensing is fast, scalable and convenient, offering the possibility to adjust the dispensing temperature according to the specific needs of each application. All our models are equipped with a peristaltic pump and are compatible with a wide range of accessories designed to enhance the dispensing speed and flow. These accessories are: the external dosing station, an automated Petri dish dispensing system, and options for one or two peristaltic pumps.

5. Automatic cleaning of dispensing lines

All our media preparators feature a continuous steam cleaning system, an innovative and exclusive design from RAYPA. This system not only simplifies the cleaning process, but also prevents the gelation of the medium and significantly lowers contamination risk. It offers the flexibility of triggering disinfection and cleaning processes of the dispensing lines before, during, and after the dispensing phase, ensuring consistent hygienic operation.



Preparation



Sterilization



Fast cooling



Dispensing



Cleaning of lines









Automation of culture media preparation

The AE-MP Series media preparators are engineered to transform the culture media preparation process by consolidating multiple stages into a single device. This integration brings substantial advantages over traditional autoclave methods, including reduced preparation time, enhanced reproducibility, and minimized contamination risk, among other critical benefits.

The following table presents a detailed comparison between culture media preparation using the conventional autoclave method and our AE-MP Series media preparators, illustrating the distinct advantages provided by our technology.

Advantages of AE-MP Series media preparators over traditional autoclaves in culture media preparation

	Traditional autoclave method	AE-MP Series media preparators
 Preparation	Many repetitive and time-consuming hand-operated steps. Weighing, filling with water and mixing each container must be done individually. Solubility and homogeneity problems in concentration and volume.	A single operation of weighing and water filling, coupled with constant stirring and precise automated dispensing, achieves perfect solubility, uniform concentration, and equal volume dispensed within all containers.
 Heating and sterilization	Low-wattage equipment with very slow heating. The lack of stirring results in uneven temperatures among the containers, increasing the risk of overheating or ineffective sterilization. The absence of internal temperature control in the containers impedes the assessment of the efficacy of the process.	Overpowered equipment rapidly heats the medium. The level of sterility achieved is the same at all points of the preparation. The use of a PT-100 flexible temperature probe for direct temperature monitoring enables quantification of lethality and ensures full traceability of every process.
 Cooling	Very long cooling phase. After opening the door, the exact temperature of the containers is unknown, with the consequent risk of burns. Thermolabile nutrients or antibiotics cannot be injected. The overexposure to heat adversely affects the fertility of the culture media.	Fast cooling system using a water coil that reduces cooling time by up to 90%. Thermolabile nutrients or antibiotics can be injected at any time and enables the configuration of cycles with additional warming intervals.
 Dispensing	Manual and individual dispensing in each container. Dispensing temperature not controllable. Notable lack of speed. Lack of homogeneity in volume between containers. Scaling up productivity in response to increased demand is challenging.	Dispensing with adjustable speed and temperature. Perfect volume homogeneity between containers. Multiple dispensing methods and the ability to attach external dispensers to scale productivity on demand.
 Safety	Risk of burns from hot flasks, breakage of containers inside the autoclave and solidification of the preparation during dispensing.	Ergonomic design, total safety for the operator, multiple automatic functions, and minimal risk of cross-contamination.
 Cleaning	Difficult and laborious. Manual cleaning of each container and of the dispensing system used.	Significant time is saved. Chamber self-cleaning program and multiple cleaning and disinfection functions of the dispensing lines before, during and after the sterilization phase. Inner vessel with handles for comfortable removal.



Benefits of AE-MP Series media preparators

Efficiency and time savings

The fast cooling system is key in our media preparators, offering up to 90% reduction in the duration of the cooling phase. To further speed up the process, we offer models with enhanced heating capacity that significantly reduce the duration of the heating phase. Moreover, the integration and automation of multiple functions within the same equipment allows to increase productivity per shift, optimize the workflow, enhance the quality of preparations and have end-to-end traceability of each batch.

Accurate and controlled sterilizations

Thanks to a flexible PT-100 temperature probe that takes measurements directly in the medium, the sterilization process can be controlled by means of programs with multiple adjustable parameters. These programs allow to regulate the time, the chamber temperature or the F_0 value. Additionally, it is possible to set the dispensing temperature and define temperature segments to meet the specific needs of different preparations. The microprocessor uses these measurements to regulate the cycle, ensuring precise and accurate control over the entire process.

Advanced safety and reduction of human error

A design focused on ensuring user safety and comfort includes features like automatic chamber door locking, thermally insulated covers, transport casters with brakes, and alarm systems for failure notifications or cycle completion alerts. Additionally, automating multiple manual processes reduces the need for human intervention, minimizing common errors seen in traditional methods, such as measurement inaccuracies, skipped steps, and technique variations between operators.

High productivity

At RAYPA, we understand that productivity is an essential factor in professional environments, where the optimization of time and resources is of utmost importance. The high production capacity of culture media per cycle, combined with an adjustable dispensing speed range from 7mL/s to 100mL/s, offers a notable advantage for streamlining workflows. This design not only boosts overall productivity but also minimizes downtime between cycles.

Professional reproducibility

By performing multiple steps automatically, executing a single weighing, and processing the entire preparation under the same conditions, much greater accuracy and reproducibility is achieved than with the traditional autoclave method.

Perfect homogeneity

It ensures a homogeneous distribution of all ingredients in the medium through the use of the integrated continuous stirring system, which offers an adjustable speed to meet various needs. Additionally, the automation of the dispensing phase allows the dispensed volume to be the same in all containers.

Wide range of models

The availability of six different models, including two benchtop and four vertical floor-standing models, with maximum production capacities ranging from 8 to 90 liters, guarantees that there is a solution for every type of laboratory. This variety allows users to select the model that best suits their specific requirements, whether in terms of production capacity or size.

Exceptional build quality

The use of high-quality components and materials in the construction of our media preparators is essential to ensure their durability, safety, and optimal performance. The sterilization chamber and the inner vessel made of AISI-316L stainless steel offer an outstanding corrosion resistance and an ease of cleaning, while the external housing made of AISI-304 stainless steel provides additional robustness. Incoloy®825 heating elements stand out for their outstanding resistance to oxidation and corrosion at high temperatures, ensuring a long lifespan and reliable performance.





Model sizes and weights

Standard AE-MP Series media preparators are available in 6 models:

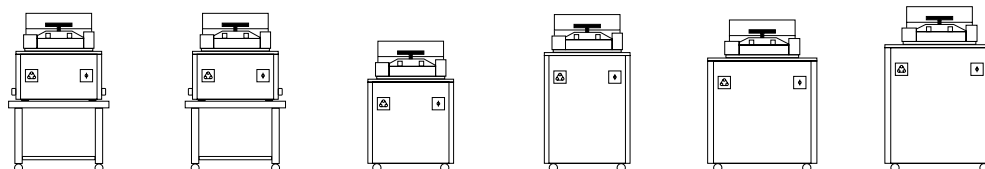

References	AE-20-MP-10L	AE-20-MP	AE-40-MP	AE-60-MP	AE-80-MP	AE-100-MP
maximum capacity for preparing culture media L	8	18	36	54	72	90
Minimum capacity for preparing culture media* (by F ₀ or by time) L	2 or 5	2 or 10	5 or 20	10 or 30	20 or 50	20 or 70
External dimensions L x D x H mm	689 x 815 x 735	689 x 815 x 735	615 x 815 x 1100	615 x 815 x 1320	755 x 935 x 1285	755 x 935 x 1385
Inner vessel dimensions Ø x H mm	210 x 236	330 x 236	330 x 461	330 x 696	420 x 594	420 x 734
Net weight Kg	125	128	135	155	244	265

*The minimum volume capacity will be much lower if sterilization is performed by F₀ instead of chamber temperature at 121°C. Contact our technical service for more information.





Understanding the operation of our media preparators

Phases of a sterilization cycle

A. Heating phase

In this initial step, the powerful electric heating elements mounted inside the sterilization chamber heat up rapidly, transferring energy to water to produce saturated steam and heat the inner vessel.

B. Sterilization phase

When the programmed sterilization temperature is reached, it is precisely maintained for the stipulated time. This step is controlled by a PT-100 temperature probe located inside the inner vessel in direct contact with the preparation.

C. Cooling phase

After finishing the sterilization phase, a fast cooling phase begins, activating the water cooling coil to cool the load rapidly until the programmed dispensing temperature is reached, which will remain constant until all the prepared culture medium is dispensed.

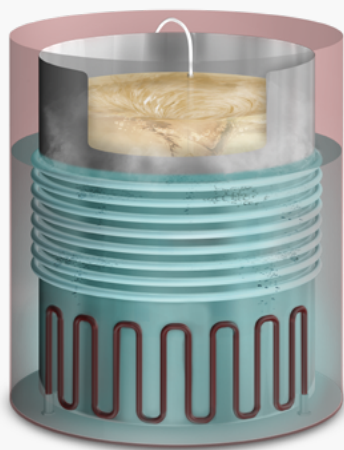
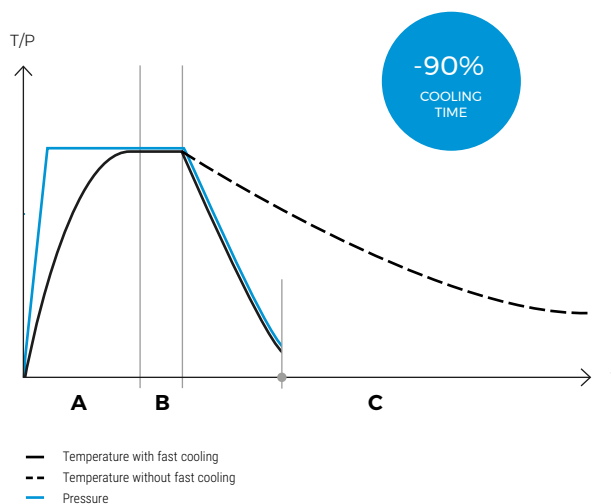

A Heating phase

The electric heating elements generate heat to produce steam and heat the sterilization chamber.

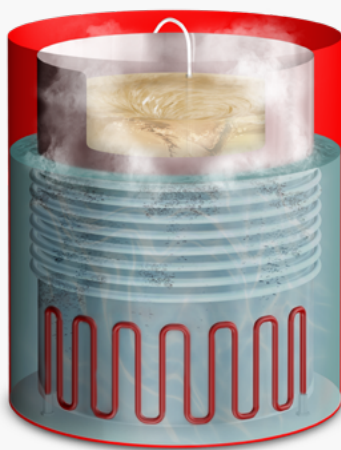

B Sterilization phase

Upon reaching the maximum processing temperature, the sterilization phase begins.

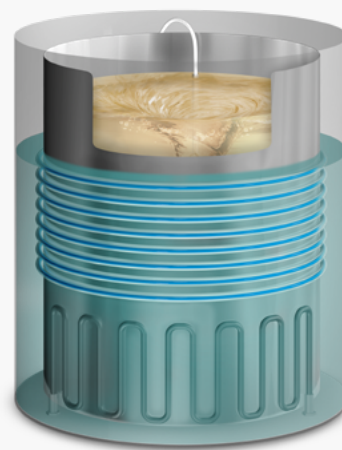

C Cooling phase

The activation of the cooling coil quickly cools the load to the dispensing temperature.

These illustrations show the three standard phases common to all AE-MP Series models. Additionally, all models offer an optional feature that introduces pressure support via an air compressor during the transition between the cooling phase and the dispensing phase when using an external dosing station. For advanced users who need to prepare more complex recipes that require the dispensation of thermolabile supplements, it is also possible to program cycles with ramps before and after the sterilization phase.



Preparation

Culture media preparation is a fundamental process in microbiology, tissue culture and biotechnology laboratories. Our standard media preparators are designed to facilitate and optimize this process, combining advanced technology with ease of use. These devices not only ensure a homogeneous preparation, but they also significantly reduce manual intervention, guaranteeing consistent, high-quality results.

Key features of these media preparators and their roles in enhancing laboratory efficiency are detailed below.

Magnetic stirring paddle system

The magnetic stirring system of standard media preparators uses specially designed paddles to ensure a constant mixing of the culture medium components. The stirring speed is adjustable between 50rpm and 200rpm, which prevents sedimentation problems and ensures a homogeneous distribution of all components in the preparation.

For high-viscosity media, we offer the ULTRA-STIRR magnetic stirring paddle system, a special adaptation with expanded paddles. This accessory employs tangential flow paddles, which prevent turbulence and ensure uniform thermal exchange throughout the solution. This system is especially useful for laboratories processing high-viscosity solutions, such as aqueous mixtures with starch, oats, or other vegetable flours.

Speed control by an independent controller

The AE-MP Series allows precise control of stirring speed via an independent potentiometer located on the control panel, with speeds adjustable up to 200rpm. This feature enables tailoring of the mixing process to the specific requirements of each culture medium, ensuring optimal conditions for solubility and homogeneity. During the initial mixing phase, the vortex remains clearly visible for easy adjustment, and stability is maintained throughout the cycle.

Inner vessel with handles for an easy extraction and cleaning

The inner vessel of the AE-MP media preparators can be easily removed, simplifying the cleaning routines.



Dispensing

Accuracy and flexibility in managing the culture media dispensing phase are critical for safe processes and maximizing productivity. At RAYPA, we understand that each laboratory has unique needs and, therefore, we offer different options for managing the dispensing phase, designed to meet different requirements and production needs:

Overview of dispensing speeds

Dispensing performance	Dispensing line model (Ø mm)	Dispensing speed
A single peristaltic pump	3,2	7mL/s
	4	9mL/s
	4,8	11mL/s
	6,4	15mL/s
	8	20mL/s
Two peristaltic pumps Ref. CAB-2	3,2	12mL/s
	4	15mL/s
	4,8	18mL/s
	6,4	25mL/s
	8	33mL/s
External dosing station Ref. DW-MP-TS		65mL/s (0,6Bar)
		76mL/s (0,7Bar)
	6,4	87mL/s (0,8Bar)
		94mL/s (0,9Bar)
		100mL/s (1Bar)

Peristaltic pump

The peristaltic pump comes standard on all our media preparators. This dispensing option is ideal for automation and acceleration of the dispensing phase in repetitive operations involving small to medium volumes. The flow rate can be doubled by installing a second peristaltic pump, thus increasing productivity. The dispensing speed achievable with this configuration ranges from 7mL/s to 33mL/s, depending on the dispensing line size and the number of peristaltic pumps installed.



External dosing station

Accessory recommended for automating and accelerating the dispensing phase in repetitive operations involving medium to large volumes. It is the ideal solution for dispensing culture media at high speed when using medium and large media preparators.

Distinguished by its accuracy and an intuitive touchscreen interface, this system simplifies the setup of dispensing parameters across various programs at different speeds and volumes.

Thanks to its design, the dispensing line can be transferred through physical barriers like glass or walls, making it ideal for sterile environments such as laminar flow cabinets or cleanrooms. It enables precise dispensing of medium and large volumes, adapting to different types of containers and applications, at speeds between 65mL/s and 100mL/s.

Reference	DW-MP-TS
Dimensions L x D x H mm	210 x 285 x 200
Weight Kg	2,85
Power W	50
Voltage V	90 - 250
Frequency Hz	50/60

The dispensing speed will depend on the density of the culture media and the chosen pressure support within the media preparator. As a guideline, the range of dispensing speeds is as follows:

Pressure support Bar	1	0,9	0,8	0,7	0,6
Dispensing speed mL/s	100	94	87	76	65





Automatic system for dispensing culture media

It is the ideal complement for microbiology laboratories that use media preparators and need to perform accurate and safe dispensing in Petri dishes. This system stands out for its ability to execute multiple processes automatically and for its safety measures: the dispensing area is protected by a safety cover and an UV-C lamp that ensures the sterility of the filling area. There are four models available with capacities ranging from 101 to 241 Petri dishes and dispensing volumes ranging from 1mL to 1000mL.



References	CAR-MP-110/60	CAR-MP-110/90	CAR-MP-280/60	CAR-MP-280/90
External dimensions L x D x H mm	600 x 610 x 650	600 x 610 x 650	600 x 610 x 990	600 x 610 x 990
Total weight Kg	50,5	50,5	53	53
Power W	350	350	350	350
Voltage V	110 - 220	110 - 220	110 - 220	110 - 220
Frequency Hz	50/60	50/60	50/60	50/60
Total capacity of Petri dishes u	101	101	241	241
Compatible Petri dishes diameter* mm	60	90	60	90
Dispensing volume ml/Petri dish	1 - 99	1 - 99	1 - 99	1 - 99
Flow rate ml/min	600	600	600	600
Maximum productivity u/h	500	500	500	500

*Through the intervention of an authorized technician and the acquisition of the necessary components, it is possible to modify the size of compatible Petri dishes from any Ø60mm model to Ø90mm and vice versa.





Automatic cleaning of the dispensing lines

One of the most significant challenges when using any media preparator is dealing with microbial contamination issues and the manual cleaning requirements associated with its use after each rotation. Fortunately for our customers, our media preparators feature an exclusive design that greatly simplifies the cleaning of the equipment and the dispensing lines, and reduces the risk of microbial contamination.

In this regard, it is essential to follow good practices and always work in the most aseptic environment possible, always dispensing the media inside a laminar flow cabinet and taking full advantage of the self-cleaning functions that our media preparators incorporate. These functions eliminate the need for disassembly, manual cleaning, and autoclaving of the lines after each use, as they use high-temperature steam to efficiently and safely clean and disinfect the lines in each sterilization cycle. The synergy of these functions significantly enhances workflow comfort, and helps to preserve more aseptic working conditions.

In fact, many of our clients prefer not to handle the dispensing lines, limiting direct interaction to scheduled deep cleaning sessions. Moreover, if the automatic cleaning functions of our media preparators are used correctly, there is no need to autoclave the dispensing lines. The proper use of the cleaning functions of our media preparators eliminates the need to autoclave the dispensing lines after each rotation. However, it is essential to replace these components periodically, as wear and tear and the passage of time increase the likelihood of breakage, the accumulation of solid residue deposits and the potential formation of biofilms.

Before dispensing

Before starting the sterilization phase, the dispensing lines undergo an automatic self-cleaning and disinfection process by applying continuous steam to minimize the risk of contamination.

The self-cleaning and disinfection function of the dispensing lines before



*If the drain is elevated and water needs to be removed from the chamber, you can enable pressure support in the predefined cleaning program settings, provided your media preparator is equipped with a CP-MP air compressor. This pressure support should be activated at the end of the program to manually open the drain. Please note that this operation should not be used in programs that include a final temperature maintenance phase, as it may interfere with its proper operation.

beginning the sterilization phase is always activated automatically. Therefore, the metal nozzle must be placed inside the bottle provided with the media preparator to avoid possible burns and to collect the condensed steam that is expelled during this procedure. After completing this step, when starting the dispensing phase, the metal nozzle should be removed from the bottle. It is very important not to use any other bottle to collect this steam than the one supplied by RAYPA.

During dispensing

Another cleaning function offered by our media preparators is the purging of the line using compressed air. This feature allows the dispensing process to be paused, emptying the dispensing line with pressurized air. It is usually used to take a break or when the operator must be absent for an extended period of time.

This purge prevents the medium from solidifying in the line, thereby avoiding obstructions when resuming dispensing. To be able to use this function, the media preparator must be equipped with the CP-MP compressed air system, which is included by default in all models with an inner vessel capacity of more than 40L.

After dispensing

All our media preparators are equipped with the predefined program P1 CLEANING, essential for daily maintenance. This program, with an approximate duration of 20 minutes, should be activated at the end of the workday or when changing the type of medium. Using continuous steam generation, the program performs a thorough cleaning of the sterilization chamber, the dispensing lines, and the internal tubing, ensuring that all components are ready for their next use.

To enhance the results of the automatic cleaning program, especially after preparing viscous media, we always recommend performing a pre-wash. To do this, 1L of distilled water should be added to the inner vessel, the stirrer should be activated, and all the water should be dispensed continuously using the peristaltic pump.

Additionally, during deep cleaning sessions, which we recommend ideally once a week, it is advisable to drain the water from the sterilization chamber, detach the magnetic stirrer, and remove the inner vessel*. These components should then be cleaned with neutral detergent and rinsed with water.



Steps to follow to enable the self-cleaning and disinfection function of the dispensing lines before the sterilization phase



1. Set the dosing selector to "CLOSED" mode.



2. Check that the dispensing line is not pinched by the peristaltic pump or the external dosing station.



3. Place the metal nozzle of the dispensing line inside the bottle supplied with the media preparator.

Steps to follow for emptying the dispensing lines during the dispensing phase



1. Set the dosing selector to "CLOSED" mode.



2. Check that the dispensing line is not pinched by the peristaltic pump or the external dosing station.



3. Place the metal nozzle of the dispensing line inside of the supplied bottle.



4. Select the purge option with pressure support.

Steps to follow to execute the self-cleaning program of the chamber, tubes and dispensing line



1. Set the dosing selector to "OPEN" mode.



2. Check that the dispensing line is not pinched by the peristaltic pump or the external dosing station.



3. Place the metal nozzle of the dispensing line inside of the supplied bottle.



4. Select the P1 CLEANING program.



High-performance sterilizations

Our standard media preparators have been specifically designed for the preparation of large quantities of culture media. All models are equipped with a powerful magnetic stirrer –adjustable from 50rpm to 200rpm–, a flexible probe, a fast cooling system via a water coil, and scalable dispensing with multiple usage options. Additionally, all units can be customized with accessories according to the specific requirements of the client, including a wide range of dispensing systems.

RAYPA exclusively uses high-quality and easily replaceable components at all stages of the design and construction of our media preparators. This approach ensures maximum operational efficiency and allows for swift after-sales service throughout the equipment's lifespan. With guaranteed optimized operability, our media preparators enhance productivity and deliver exceptional return on investment.

Steam generation

Standard media preparators produce steam automatically by means of electrical heating elements mounted inside the sterilization chamber. An external steam source is not required. The filling of the sterilization chamber with water can be managed manually or automatically by installing the KLL-MP automatic water filling kit at the factory to supply the sterilization chamber from a tank or directly from a purified water network. In some instances, the automatic filling of the sterilization chamber can be achieved without needing the KLL-MP accessory.

The electric heating elements are made of Incoloy®825, a nickel-iron-chromium alloy with additions of molybdenum, copper and titanium. This alloy provides an exceptional level of corrosion resistance in both moderately oxidizing and reducing environments, along with excellent resistance to aqueous corrosion.

Depending on the model, the standard available voltages are 230V or 400V, with both single-phase and three-phase connection (Annex 1). In addition, we offer specific electrical plugs and voltages adapted to the customer requirements outside the European Union.

At the start of a cycle, the sterilization chamber is filled with water to cover the heating elements. Water is then added to the inner vessel, the stirring system is activated, and all components of the culture media that can undergo sterilization are introduced. Thermolabile components should be added after the sterilization phase, either by syringe or direct decanting through the designated ports. During the heating phase, saturated steam is produced in the sterilization chamber and heats the inner vessel. A water level buoy monitors that the electrical heating elements are covered with water during normal operation of the equipment and will generate an alert in case of failure.

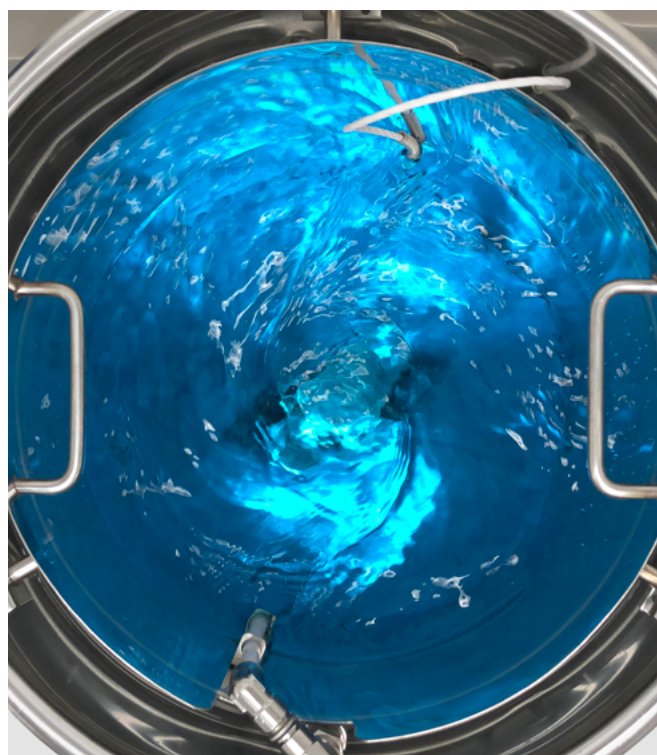

Water quality compatibility

For a proper operation, standard media preparators require decalcified and contaminant-free water to supply the cooling coil in order to avoid the formation of calcareous residue deposits inside the system. On the other hand, the water used to supply the media preparator and generate steam must be purified.

TYPE OF WATER	MG/L ¹	FH ²	DH ³	EH ⁴
Soft water	≤17	≤1,7	≤0,95	≤1,19
Slightly hard water	≤60	≤6,0	≤3,35	≤4,20
Moderately hard water	≤120	≤12,0	≤6,70	≤8,39
Hard water	≤180	≤18,0	≤10,05	≤12,59
Very hard water	>180	>18,0	>10,05	>12,59

¹ Mg/L: calcium carbonate (CaCO₃) milligrams per liter of water.

² FH: French hardness (10,0 mg CaCO₃/L).

³ DH: German hardness (17,8 mg CaCO₃/L).

⁴ EH: English hardness (14,3 mg CaCO₃/L).

For customer settings that do not have access to soft water, we offer a validated water softener (WATERSOFT-MP) compatible with our media preparators.



Sterilization with F_0 regulation

In the field of microbiology and biotechnology, the correct preparation and sterilization of culture media are fundamental steps to ensure the integrity and efficiency of microbiological cultures, as well as plant and cell tissue cultures. While some preparations can withstand more aggressive sterilization processes without suffering a significant deterioration in their composition, there are others that are more sensitive to heat and require more delicate processing to preserve both their fertility rate and physicochemical properties. To address this need, our media preparators offer the ability to program sterilization cycles not only based on chamber temperature, but also through a more advanced technique: F_0 value-managed sterilization.

The variability of a sterilization process

Quantifying the degree of microbiological destruction achieved by a thermal process is not simple. Each microorganism has a different thermal resistance, and each type of medium has particular characteristics that affect its thermal conductivity. Moreover, variables such as pH and the nature of the processed medium influence the fact that, to achieve an equivalent degree of microbiological destruction, it is necessary to use different combinations of temperature and exposure time.

A critical aspect to consider is the significant latency between the temperature evolution in the sterilization chamber and that of the medium itself. This difference is especially noticeable when the volume of the prepared culture medium is large; for example, 40 liters are not heated as quickly as 90 liters.

To minimize the impact of these factors on the quality of the process, it is essential to use a flexible probe inserted directly into the medium to accurately monitor the evolution of the culture media temperature and adjust the process accordingly. Additionally, if the cycle can be regulated by F_0 , the probe readings captured by the flexible probe enable the accurate calculation of the lethality obtained during a given process.

To understand how our media preparators perform sterilization with F_0 regulation, we must first understand the concepts of F_0 , D-value, and Z-value.



F_0 value

The central parameter of sterilizations by F_0 is the F_0 value, and is used to quantify the lethality of a sterilization process. The F_0 value represents the equivalent minutes of sterilization at 121,1°C. For example, a sterilization cycle with a F_0 of 3 indicates a process that is equivalent to subjecting a load to 121,1°C for 3 minutes. However, following this example, a F_0 of 3 is also equivalent to 12 minutes at 115°C or 5 minutes at 119°C. In other words, sterilizing for 3 minutes at 121,1°C is equivalent to sterilizing for 12 minutes at 115°C or 5 minutes at 119°C.

This concept allows to quantify in real time the sterility achieved within the culture media and adjust the sterilization process according to the particular needs of what is being sterilized. Additionally, when F_0 -regulated sterilization is used in conjunction with a central probe, the temperature of the medium can be measured and the sterilization process can be regulated by the F_0 value obtained in the medium itself and not by the chamber temperature, avoiding efficiency errors due to too short exposures.

The formula to calculate the F_0 value is as follows:

$$F_0 = \Delta t \sum 10^{\frac{T-121}{z}}$$

Δt = time interval between two consecutive measurements of T
T = temperature of the sterilized product at time t
z = temperature coefficient, usually assumed to be 10°C

D-value

D-value, also known as decimal reduction time, indicates the thermal susceptibility of a microorganism at a constant temperature. This value is defined as the minutes required to destroy the 90% of the microorganisms present in a sample. For example, a D value of 1 represents a reduction of 90%, a D=3 represents a reduction of 99,9% and a D=6 means a reduction of 99,9999%. In practice, it is common to work with a D=1, so it is not always explicitly mentioned in formulas.

The number of microorganisms present before the sterilization or pasteurization process can be very high. In fact, it is usually so high that it is commonly expressed in powers of 10 to avoid writing a large number of zeros (1.000 is written as 10^3 , and 10.000.000 is written as 10^7).

The process of destruction of microorganisms starts at relatively low temperatures, such as 65°C. To reduce the initial number by one decimal place, it would be necessary to expose the medium to 65°C for a specific time, for example, 20 minutes.

Now suppose that initially a sample contains 10^6 microorganisms (1.000.000); after 20 minutes at 65°C, the number of microorganisms would be reduced by 10 times, resulting in 10^5 (100.000). If the process is repeated for another 20 minutes, the number of microorganisms would be reduced again by 10 times, remaining at 10^4 (10.000). This means that, after two cycles of 20 minutes each, the number of microorganisms would have been reduced by 100 times compared to the initial value.



Z-value

The Z-value, known as the thermal resistance factor, indicates how the inactivation of a specific microorganism changes when the temperature of a process is modified. The inactivation caused by a sterilization process at 120°C for one minute is entirely different from what would occur at 110°C over the same time period.

As the temperature increases, the number of microorganisms destroyed per minute rises drastically. Depending on the species of microorganism, it can be experimentally determined the temperature increase required to reduce the D-value by a factor of 10 (in our example, from 20 minutes to only 2 minutes); this temperature increase is represented by the Z-value and is expressed in °C.

In other words, the D-value is the time (t) required at a specific temperature (T) to reduce the microbial population from 100% to 10% (logarithmic reduction of 1). The Z-value is the number of degrees that the temperature must be increased to cause a 90% reduction in the D-value. In moist heat sterilization, Z-values range from 6 to 13 for temperatures between 100°C and 130°C. A 1°C change in this range implies a ~26% variation in the D-value, which highlights the significant impact of small temperature variations.

This temperature variation effect diminishes as the temperature increases or if the sterilization method is changed. For example, the Z-value for dry heat sterilization at 200°C is approximately 20. Therefore, small temperature differences are critical in moist heat sterilization, but less significant in dry heat sterilization.

Advantages of working with F₀

The use of F₀ programs in sterilization processes within the AE-MP Series media preparators offers several advantages that optimize both the quality of the final product and the efficiency of the process.

Some of the main advantages are listed below:

- **Preservation of culture medium quality.** By applying F₀ sterilization techniques, the lethality achieved at each stage of the process is precisely quantified, including the phases before and after the plateau in the temperature curve. This prevents overheating or "overcooking" of recipes, ensuring that sensitive ingredients are not exposed to excessive temperatures. This precision in thermal control is crucial for maintaining the physicochemical and biological properties of the culture medium, resulting in higher-quality products.
- **Energy savings and process time reduction.** Efficiency is a key factor in any sterilization process, and the use of F₀ programs excels in this regard. By enabling an accurate regulation based on the F₀ value, the time required to reach the desired sterility is optimized without unnecessarily prolonging the heating or sterilization phase of the cycle. This means a significant reduction in energy consumption and an improvement in production times, allowing an increase in production capacity without increasing operational costs.
- **Uniform lethality regardless of volume or formula.** One of the great advantages of F₀ programs is that they ensure the same effectiveness in microorganism destruction, regardless of the volume of the culture medium or the specific formula in use. That means that laboratories can handle batches of different sizes and compositions without worrying about variations in the quality of the sterilization process.
- **Flexibility in the preparation of smaller volumes.** Unlike traditional methods that rely on the temperature of the sterilization chamber, the use of F₀ programs makes it possible to work with much lower minimum volumes in our standard media preparators. The explanation behind this is due to the ratio between the volume of air, steam and the volume of media. The underlying technical explanation for this effect involves complex factors that exceed the scope of this document. This is particularly useful in applications that require the preparation of small batches for specific tests.
- **Traceability and process control.** The use of the flexible probe in combination with cycle regulated by F₀ allows a direct monitoring and recording of the temperature and lethality achieved within the culture medium, providing a complete traceability of the sterilization cycle. This detailed control capability is essential to meet quality standards and regulatory guidelines, ensuring that each prepared batch can be audited and verified as to its sterilization process.
- **Reduction of human error and variations due to different techniques between different operators.** F₀ programs automate much of the process, minimizing the need for manual intervention and thereby reducing the risk of human error or operator technique. This not only enhances operator safety, but also ensures greater consistency of results, which is crucial in environments where accuracy is essential.



Pressure control

In any autoclave or media preparator, pressure control is essential to ensure the efficacy of the sterilization process. In the specific case of our media preparators, the models equipped with a built-in air compressor can set programs with a pressure support between 0,1Barg and 2,2Barg during the fast cooling and dispensing phase, in order to speed up the dispensing phase.

The chamber pressure value is displayed both on the analog pressure gauge integrated into the panel and on the controller screen, highlighted in blue for an easy identification.

Furthermore, activating this functionality will influence the correct dispensing of supplements, pH correctors or antibiotics, allowing a controlled injection of these substances through the addition port located on top of the lid.

The AE-60-MP, AE-80-MP and AE-100-MP models are equipped as standard with a compressed air system that injects additional pressure. In contrast, in the AE-20-MP-10L, AE-20-MP and AE-40-MP models, this system must be purchased as an accessory, with reference CP-MP, and must be installed at our factory.

This adjustable pressure support value plays a key role in the following operations:

- **Dispensing with an external dosing station.** Pressure support is required in order to work with this accessory. The external dispensing station automates and accelerates the dispensing phase in repetitive operations involving medium and large volumes.
- **Purge of the dispensing line.** This procedure is performed to stop the dispensing process, whether for a break or due to an unforeseen event. Any liquid present in the dispensing line is expelled via pressure support.
- **Injection of nutrients, pH correctors or thermolabile antibiotics after the sterilization phase.** As the pressure support value increases, the injection of supplements through the addition port becomes more laborious.

Temperature control

The chamber temperature is displayed on the screen at all times, facilitating continuous monitoring of the process. Our standard media preparators allow precise adjustment of the sterilization temperature for each cycle, within a range of 50°C to 125°C. This fine control ensures optimal conditions for process efficiency and provides flexibility to perform cycles with lower peak temperatures, suitable for thermolabile supplements.

Options to control temperature

To guarantee an accurate temperature control, our standard media preparators equip two systems to control temperature:

- **Flexible probe:** this probe is placed in direct contact with the media to obtain accurate readings of the temperature of the culture media.
- **Chamber probe:** located inside the sterilization chamber, this probe measures chamber temperature.

The sterilization cycle can be controlled in two ways:

- **By time:** This method controls the cycle by maintaining a fixed temperature for a predetermined time, based on the flexible probe measurements. It ensures that the medium is maintained at constant conditions to guarantee the sterilization.
- **By F_0 value:** This method optimizes the cycle by adjusting the duration based on the actual temperature and conditions. Through flexible probe measurements, it combines exposure time and accumulated temperature to effectively eliminate microorganisms without compromising the integrity of heat-sensitive components.

Protection against power fluctuations or outages

In the event of electrical interruptions, such as power outages or fluctuations, our standard media preparators are designed to handle these events safely. If a power loss occurs, the equipment shuts down in a controlled manner, preserving the state of the cycle. Once power is restored, the system allows the cycle to resume from where it was interrupted or restart as needed.

For customers located in regions prone to suffer these problems on frequent basis we offer two accessories designed to protect the equipment and ensure the continuity of the sterilization cycle in case of intermittent power fluctuations or outages:

- **EMC-FILTER:** This filter is used in areas with voltage fluctuations and is mandatory to include in some countries to protect the equipment. All 115V devices include this filter as standard, while in 220V or three-phase equipment, its inclusion depends on the region. The EMC-FILTER is essential to prevent damage to electrical components caused by variations in the power supply.
- **UPS (Uninterruptible Power Supply):** This system is automatically activated in the event of a power outage, allowing the equipment to continue operating without interruption. There are three available models: SAI-250, SAI-900 and SAI-4000. SAI-250 and SAI-900 models are designed for brief outages, of less than one minute, keeping the display on without supplying power to the heating elements. On the other hand, the SAI-4000 model is ideal for customers who anticipate longer power outages, of more than one minute, as it can keep the equipment in normal operation for 5 to 10 minutes, ensuring power to the heating elements and other essential components of the media preparator.

Versatility and mobility between rooms

In addition to its accuracy and safety, our standard media preparators stand out for their versatility. All models include casters or can be equipped with a table with wheels, making them easily transportable between different rooms, allowing to start the preparation in one room and upon completing the sterilization cycle and reaching the dispensing phase then move the equipment to a cleanroom to perform the dispensing phase with the preprogrammed holding temperature, with no time limit. This mobility enables a flexible integration into different workflows within the laboratory, maintaining the sterility and quality of the prepared medium at all times.

Additional safety

Finally, to ensure maximum safety, our standard media preparators are equipped with a safety thermostat that automatically interrupts the process if the temperature exceeds the set limits, preventing damage due to overheating. This system, along with operator alerts, ensures safe and efficient operation at every stage of the process.



Fast cooling

After the completion of the sterilization phase, the equipment initiates a fast cooling phase, activating the water cooling coil to quickly cool the load until it reaches the dispensing temperature. This feature reduces the duration of this phase by up to 90% compared to a natural cooling process.

The water used in the fast cooling system, that circulates inside the cooling coil, generally does not require active cooling, but in places with extremely hot climates where the mains water can exceed 35°C, such as the Middle East or African countries, or in areas with significant temperature fluctuations between seasons, it is advisable to use a dedicated water circuit or a water tank with a chiller; this shortens the duration of the cooling phase and minimizes fluctuations in processing times with seasonal changes. The warmer the water supplied to the cooling coils, the slower the cooling phase.

If a dispensing temperature has been programmed, upon reaching it, the equipment will stop the fast cooling system and activate the electrical heating elements to maintain that temperature constant indefinitely until the entire preparation has been dispensed. The dosing temperature can be set between 30°C and 100°C. If the program is regulated by flexible probe, the end of cycle temperature corresponds to the temperature of the medium. If the process is controlled directly by the chamber, the end of cycle temperature corresponds to the chamber temperature.

At the end of the cooling phase, the dosing selector can be opened to start dispensing with any of the available dispensing methods: peristaltic pump, external dosing station or automatic dispensing system for culture media in Petri dishes.

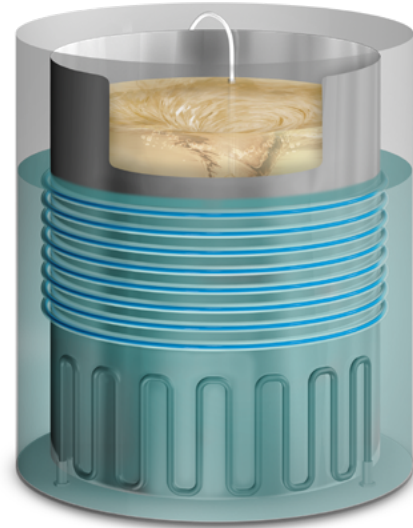

Cooling phase

After the sterilization phase, cold water automatically flows through the cooling coil to drastically reduce the temperature of the preparation until the dispensing temperature is reached.

Impact of the fast cooling system on the duration of a sterilization cycle

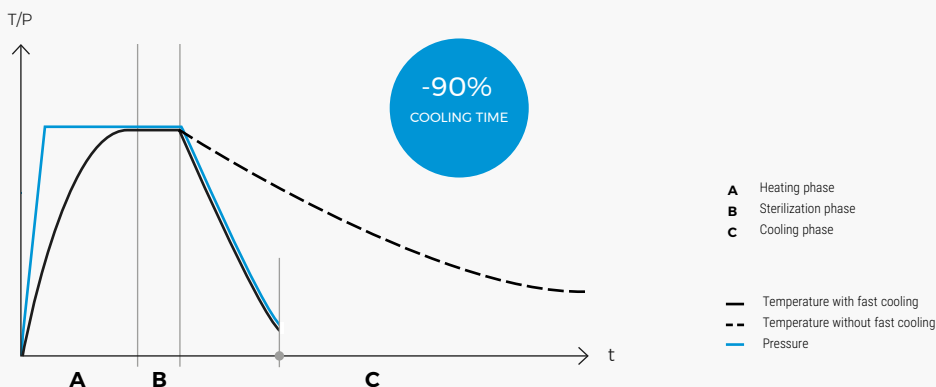



Programs with multiple ramps

Optionally, the cooling phase can be structured in multiple ramps, each with a specific set of time, pressure and temperature conditions. In the AE-MP Series media preparators, the multiple ramp mode is hidden to simplify the usability of the equipment; however, it can be activated upon request. The transition between these ramps can include stabilization stages to ensure controlled and uniform cooling of the load.

In the microbiology industry, sterilization cycles with ramps are used for preparing special culture media containing thermolabile substances. In this way, the culture medium is first sterilized, the preparation is cooled, and then thermolabile antibiotics or nutrients are injected before raising the temperature again to pasteurize the preparation.

A classic example is the preparation of blood agar. In this case, it must first be sterilized at 121°C for 15 minutes and then cooled to 50°C. The blood is then injected, pasteurized for 15 minutes at 72°C, and finally cooled back down to 45°C.

To facilitate these processes, the AE-MP Series media preparators are equipped with two specific ports. The first port is designed for the safe injection of liquids using syringes, allowing the precise addition of sensitive substances such as antibiotics or nutrients once the medium has reached the appropriate temperature. The second port is intended for decanting or sample removal, allowing controlled and contamination-free handling of the prepared medium. These ports ensure that the injection and extraction phases are carried out efficiently and in a sterile manner, thus optimizing the quality of the final culture medium.



Single ramp program for blood agar preparation

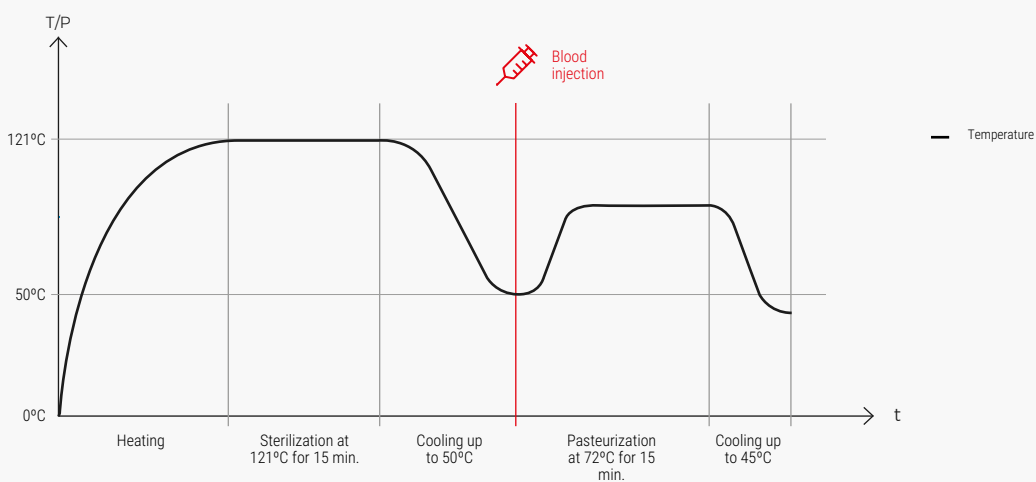



Construction quality



Sterilization chamber

Our standard media preparators are manufactured with a sterilization chamber and an inner vessel made of high-quality AISI-316L stainless steel, a steel alloy that is extremely resistant to corrosion. All sterilization chambers are electropolished with a high-smoothness, glossy finish to maximize the service life of the equipment and facilitate the cleaning of the chamber. All sterilization chambers are welded and built in compliance with the Pressure Equipment Directive (PED) 2014/68/EU of the European Union and the AD 2000 Merkblatt design codes.

Gasket and door

Our standard media preparators are designed with redundant, independent mechanical and software features to ensure maximum user safety. The door design specifications comply with the Pressure Equipment Directive (PED) 2014/68/EU of the European Union and the AD 2000 Merkblatt design codes:

- The standard media preparators use solid silicone gaskets that do not require high-pressure air, steam, or vacuum to operate. The act of closing the door compresses the silicone gasket to create a secure and reliable seal. In the event of a gasket failure, the door can be easily unlocked and the gasket can be quickly replaced.
- The door is operated by a manual wheel that guarantees a secure hermetic seal.
- The door is covered by a heat-resistant insulating plastic that remains at a safe temperature.
- Full door locking is achieved by manually rotating the wheel until a beep sounds. Moreover, door closure is confirmed by a message on the display.
- An electric door switch ensures that the door is fully closed and locked before the start of the cycle. If the signal is lost during a sterilization cycle, the cycle will be automatically cancelled.
- The safety piston is activated by chamber pressure to lock the door. Chamber pressure forces a cylinder against the clutch disc, activating the lock and preventing the door from opening.

Components

- All parts and components subject to wear and repair are stocked at our facility for quick delivery upon request.
- The sterilization chamber door cover provides thermal insulation against thermal shock.
- The easy-to-read pressure gauge is located on the control panel.

Assembly of the media preparator

Our standard media preparators are built with an AISI-304 stainless steel superstructure. On top of the external housing, insulated from temperature, a plastic control panel contains the microprocessor, the pressure gauge, the power button, the touchscreen, and the Ethernet and USB ports.

We recommend complementing the AE-20-MP-10L and AE-20-MP benchtop models with the TABLE-MP table for media preparators, equipped with casters and brakes. This table is designed to raise the media preparators to an optimal height for handling.



Controller and monitoring system

RAYPA offers a state-of-the-art control system built from industry-standard components, with proven reliability, based on a 5" TFT platform and enhanced with a touchscreen and an intuitive user interface. The standard media preparators include 3 predefined programs: CLEANING, AGAR, and AGAR F-20. Additionally, they include 47 other editable programs.

	CLEANING	AGAR	AGAR F-20
Sterilization temperature °C	105	121	121
Sterilization time min	5	20	F=20
Sterilization modalities	Liquids	Liquids	Liquids
Final temperature °C	-	60	60
Pressure support during cooling and dispensing phases* Bar	-	0,8	0,8

*Adjustable parameter in units equipped with the CP-MP air compressor.

Adjustable parameters

System parameters:

- System date and time.
- Language: English, Spanish, French, Catalan, Italian, Basque and German.*
- Ethernet parameters: IP, Mask, Gateway and Port.

If the cycle is time-controlled, the following program parameters can be set:

- Program name.
- Sterilization temperature: 50-125°C.
- Dispensing temperature: 30-100°C.
- Pressure support: constant pressure up to 1Bar.
- Multiple ramps: 0-10 segments (5 ascending and 5 descending).
- Duration of the sterilization phase: 1-250 min.

If the cycle is governed by F_0 , the following program parameters can be set:

- Program name.
- Sterilization temperature: 50-125°C.
- Dispensing temperature: 30-100°C.
- Pressure support: constant pressure up to 1Bar.
- Multiple ramps: 0-10 segments (5 ascending and 5 descending).
- Final F_0 value and Z-value for F_0 -regulated sterilization.

*Other languages can be installed upon request.

Cycle safeguards

The following safety elements help ensure safe and proper operation:

- **Open door sensor.** No cycle can start unless the door is properly closed and locked.
- **Pneumatic door locking system.** The door cannot be opened while there is positive pressure inside the sterilization chamber.
- **Integrated sterilization process evaluation system.** The sterilization process parameters are continuously checked and, in case of anomaly, the program is cancelled and fault and alarm messages are generated.
- **Pressure gauge.** Displays the pressure in the sterilization chamber and is mounted on the control panel.
- **Safety thermostat with manual reset.** In case of overheating of the heating elements, it cuts off the equipment's power supply.

Calibration

All temperature and pressure sensors on the media preparator can be calibrated via the microprocessor screen. Access to these settings is password-protected and only available to authorized technicians. Periodic calibration of the temperature probes is required.

Updates

The system can be updated via USB, allowing the end user to access future equipment upgrades on demand.





Data management

Printer

Optionally, a thermal printer can be integrated into the main control panel. The printed tickets include all relevant information from the recorded cycle: program number, cycle number, temperature, date and time of each sterilization, and error messages. When installing this accessory, a window will appear on the microprocessor screen of the equipment, allowing users to select the data capture cadence between 10 and 240 seconds. It also offers the possibility to choose 2 printing modes through the media preparator screen:

- **Simplified printing at the end of a cycle:** the ticket is printed when thermal processing has ended and it includes essential information.
- **Extended printing during cycle:** the ticket is printed continuously, within the predefined interval, and includes extensive information with detailed parameters evolution.

An external dot matrix printer option is also available. This option also includes all the important information about the recorded cycle –program number, cycle number, temperature, time, date and time of each sterilization and error messages– and allows to select the printing rate between 10 and 240 seconds.



Automatic USB backup

The media preparator automatically stores up to 200 process logs in its internal flash drive. If a USB memory stick is connected to the unit, backup copies of these logs can be saved on the USB memory stick as required.



SWMP Software

For standard media preparators, we offer an optional software that allows the analysis and recording of each cycle's data. This software, once installed, enables real-time viewing and detailed data logging. Users can export this data into reports in .CSV and .PDF formats. The software is connected via Ethernet, although it is also possible to export the data directly to a USB memory stick.

The generated reports provide graphical and numerical details on the evolution of various parameters such as chamber temperature, flexible probe temperature, chamber pressure and F_0 values. They also include relevant information such as equipment identifier, serial number and program used. Users can adjust the data capture frequency from one second and modify the time scale of the reports.

To guarantee security, access to the software requires a user name and password. Additionally, it is available in several languages, including English, Spanish, French, and Italian.





Strategies to increase productivity

There are multiple strategies to produce a larger amount of culture medium in less time, which is a priority for any laboratory. Below are some of the strategies we recommend and that our customers use.

Dispensing options

Dispensing in standard media preparators can be adapted in a variety of ways to meet the specific needs of each user. This flexibility allows the selection of the most suitable dispensing method according to the requirements of the process or application.

Peristaltic pump

All media preparators are equipped as standard with a peristaltic pump, which facilitates precise media dispensing. For those processes that require a higher flow rate, there is the option of incorporating a second peristaltic pump, thus doubling the dispensing capacity. The operation of these pumps can be manual, via a foot pedal, or semi-automatic, using a delay system.

External dosing station

This accessory has been designed to automate and optimize dispensing in tasks involving medium and large volumes, making the process more efficient in repetitive operations. Similar to peristaltic pumps, it allows a manual dispensing using a foot pedal or a semi-automatic operation using an optical sensor. To use the external dispensing station, the models must be equipped with a compressed air system. The compressed air system is included in the AE-60-MP, AE-80-MP and AE-100-MP models. On the AE-20-MP-10L, AE-20-MP and AE-40-MP models, the CP-MP accessory must be acquired independently and installed at our factory.



Automatic system for dispensing culture media

This system represents an advanced solution for microbiology laboratories that require precise and safe dispensing in Petri dishes. It is distinguished by its automation in the execution of multiple processes, increasing the efficiency and safety of the laboratory. The dispensing area is equipped with a safety cover and a UV-C lamp to maintain sterility. Four different models are available, with capacities ranging from 101 to 241 Petri dishes of either 60mm or 90mm diameter.



Overview of dispensing speeds

Dispensing performance	Dispensing line model (Ø mm)	Dispensing speed
A single peristaltic pump	3,2	7mL/s
	4	9mL/s
	4,8	11mL/s
	6,4	15mL/s
	8	20mL/s
Two peristaltic pumps Ref. CAB-2	3,2	12mL/s
	4	15mL/s
	4,8	18mL/s
	6,4	25mL/s
	8	33mL/s
External dosing station Ref. DW-MP-TS	6,4	65mL/s (0,6Bar)
		76mL/s (0,7Bar)
		87mL/s (0,8Bar)
		94mL/s (0,9Bar)
		100mL/s (1Bar)



Special versions with increased heating capacity

This option only applies if the media preparator has not yet been purchased. Models with enhanced heating capacity have been designed for professional users with high production needs who are seeking to increase their productivity by reducing cycle time. Increasing the heating capacity of the models shortens the duration of the heating phase. The exact time savings that can be achieved by equipping the unit with more powerful electric heating elements vary by model, but it can range from a 20% to 50% reduction in the duration of the heating phase. It is important to emphasize that increasing the power of the media preparator may result in changes to the electrical outlet and installation requirements.

Special versions for culture media formulas of high-density

The processing of high-density culture media presents unique challenges, requiring equipment with special features to ensure proper mixing and dispensing. The TURBO-MP version of the AE-MP Series media preparators is specifically designed to address these challenges. Thanks to structural changes to the chassis, the addition of new functions, the installation of a ULTRA-STIRR magnetic stirrer with expanded paddles and a powerful peristaltic pump, enables homogeneous mixing even in high-viscosity or lumpy media. TURBO-MP preparators are the ideal choice for laboratories that work with aqueous solutions containing starch, oat or other vegetable flours.

Special dispensing lines adapted for use in multiple workstations

The dispensing lines of our media preparators are specifically designed for the transfer of culture media without compromising sterility, allowing operation through physical barriers, such as glass walls or separations between different work areas, while maintaining a continuous and safe flow of culture media.

These lines, made of MVQ-type silicone capable of withstanding temperatures up to 200°C and with a hardness of 60A, ensure process integrity throughout the transfer process.

In addition, the dispensing lines can be customized to meet the specific needs of each customer, including options such as the extension of the line length and the incorporation of branch lines that enable the supply of culture media to multiple workstations from a single media preparator.

Integrated chiller for faster cooling

In laboratories located in regions with warm climates or in facilities where the ambient temperature is high, the use of a chiller in the fast cooling system's water supply can be very beneficial. This system cools the water circulating through the cooling coil inside the media preparator, ensuring that the temperature of the culture medium is reduced swiftly after the sterilization phase. Fast cooling not only saves time, but is also crucial to avoid the degradation of thermolabile components present in the culture medium. By keeping the cooling water at an optimal temperature, the chiller allows more precise control of the cooling process.

Use of self-cleaning functions

The self-cleaning functions of the dispensing lines are a key feature of the AE-MP Series media preparators, designed to keep the equipment in optimal operating conditions and reduce the manual workload for laboratory staff. This system uses high-temperature steam to automatically clean the dispensing lines and the sterilization chamber, removing culture media residues and minimizing the risk of cross-contamination. It is essential to use this function after each cycle, especially when working with high-density media or in environments that require high aseptic standards. The proper use of the self-cleaning functions not only ensures that the equipment is ready for the next cycle but also prolongs the lifespan of the dispensing lines by preventing the accumulation of residues that could affect their operation. Integrating this practice into the daily laboratory routine not only improves operational efficiency during routine cleaning operations, but also helps to maintain the consistency and quality of the prepared media.

Rotational use of multiple media preparators

For laboratories that need to consistently produce large volumes of culture media, the rotational use of multiple media preparators is an excellent strategy employed by many of our customers. This practice involves the sequential or simultaneous operation of multiple units, allowing for continuous production without significant downtime between cycles. By rotating units, it is possible to start a new cycle on one unit while another is in the cooling or dispensing phase, and another is being cleaned or serviced, thus maximizing the productive capacity of the laboratory. This strategy is particularly useful in environments where culture media preparation is a critical task that cannot be interrupted during shifts.

Scheduled startup

Scheduled startup is a feature that enables laboratories to optimize the use of time and resources, especially outside of working hours. With this option, operators can schedule the start of a sterilization cycle to coincide with the beginning of the workday, so that the cycle ends just before the next shift begins. This ensures that the culture media is ready for dispensing at the start of the workday, allowing technicians to make the most of their working hours. This strategy is ideal for laboratories that operate on intensive schedules or seek to maximize productivity.



Accessories

General

Eco-efficient water purifier ECOPUR-MP

Direct production reverse osmosis purifier without water accumulation designed to prevent residues or salts from depositing inside the pipes and the sterilization chamber.

The ECOPUR-MP water purifier is especially useful for users with media preparators equipped with the KLL-MP automatic water filling kit and a non-purified water network. This way, the purified water supply to the sterilization chamber will be automated.



Download ECOPUR-MP
technical data sheet

Automatic water filling kit KLL-MP

Water pump for automating the supply of the sterilization chamber with purified water. The filling of the inner vessel will not be automated.

Compatible with installations that have a purified water network, a purified water tank or installations that have a non-purified water network; in the latter case, the kit must be supplied with two additional accessories: a water purifier and a purified water tank.



Download KLL-MP
technical data sheet

Compressed air system CP-MP

Pressure support system to enable dispensing via the DW-MP-TS external dosing station in units smaller than 60L. Larger models already include it as standard. Once installed, the pressure support function can be activated on the controller, and a new optional icon appears for purging the dispensing lines during the dispensing phase, allowing a pause without the inconvenience of the medium gelling.



Download CP-MP
technical data sheet

Table for media preparators TABLE-MP

High-resistance AISI-304 stainless steel table with rubber casters with brakes to reduce noise and prevent floor wear. Designed to elevate AE-20-MP-10L and AE-20-MP media preparators to an optimal height for the user. It can also be used for a wide variety of purposes, such as:

- Mobile workstation and support for auxiliary instruments.
- Temporary storage of instruments, equipment and materials.
- Transport of heavy equipment.
- Cleaning station for laboratory instruments and equipment.



Download TABLE-MP
technical data sheet



Transport trolley

TR-TR

Durable and practical trolley with textured shelves that prevent the load from moving, and rubber casters to reduce noise and prevent floor wear. It can be used for a wide variety of tasks, such as:

- Transport of samples, materials, equipment and machinery.
- Temporary storage of equipment and materials.
- Organization of the workspace.



Download TR-TR
technical data sheet

Enhanced paddle system

ULTRA-STIRR

Special adaptation of the magnetic stirrer with expanded paddles. It consists of a tangential flow paddle agitation system designed to prevent the generation of turbulence. It is ideal for achieving uniform and efficient thermal exchange for the entire solution.

It is recommended for applications that require processing high-viscosity solutions such as aqueous solutions with starch, oats, or other vegetable flours.

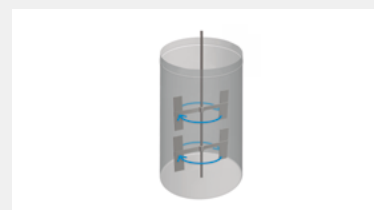

Download ULTRA-STIRR
technical data sheet

Dispensing

Automatic system for dispensing culture media

CAR-MP

Our automatic system for dispensing culture media, is the ideal complement for microbiology laboratories that use media preparators and need to perform precise dispensations in Petri dishes.

This system stands out for its ability to execute multiple processes automatically, thereby freeing laboratory staff from these tasks and significantly increasing the overall efficiency of the laboratory.



Download CAR-MP
technical data sheet

External dosing station

DW-MP-TS

Equipment constructed and designed for use inside a laminar flow cabinet in laboratories that dispense culture media. It allows for the automation and acceleration of the dispensing phase in repetitive operations of medium and large volumes.

The dispensing speed will depend on the density of the culture media and the chosen pressure support within the media preparator; as a guideline, the dispensing speed fluctuates between 65mL/s and 100mL/s.



Download DW-MP-TS
technical data sheet



Additional peristaltic pump

CAB-2

This option is perfect for applications like the production of test tubes in microbiology, where small to medium volumes are dispensed with each use.

Depending on the combination of the chosen tube size and the number of installed peristaltic pumps, the dispensing speed in this mode ranges between 7mL/s and 33mL/s.



Download CAB-2
technical data sheet

Additional sets of dispensing lines

TUB-DOSIF

Silicone dosing tubes 2m in length with press-fit connection at one end and metal nozzle at the other end. Available diameters are 3,2mm; 4mm; 4,8mm; 6,4mm and 8mm. Special adaptations can be made, such as the installation of bifurcations to dispense media in multiple cabinets.

The purchase of additional dispensing lines is recommended to increase the dispensing speed when dispensing by peristaltic pump, to avoid stopping production due to cleaning and to replace worn tubes. All media preparators include a standard set of 2 dispensing lines of Ø6,4mm and Ø8mm.



Download TUB-DOSIF
technical data sheet

Splitting of dispensing lines

BIF2-MP

Custom modification to divide the dispensing lines, enabling the supply of two distinct workstations from a single media preparator.





Data logging

Software for standard media preparators

SWMP

Communication software between the equipment and the PC available in English, Spanish, French and Italian. Allows the visualization and printing of the processes carried out. Specifically, it allows the analysis of the data of each cycle and an intuitive display of the information of the performed cycles: batch record, outcome, probes temperature, pressure, serial number, autoclave model, errors, etc. In addition, it offers two options for data extraction through report generation:

- Generation of reports in .PDF format
- Generation of reports in .CSV format



Download SWMP
technical data sheet

Embedded thermal printer

IT/MP

Allows quick printing of the most relevant results from each sterilization cycle, with a selectable printing cadence between 10 and 240 seconds: program number, cycle number, temperature, time, date and time of each sterilization, and error messages.

Recommended for registering the quality of the performed processes, in situations where the use of a computer with SWMP software is not feasible (lack of internet, room conditions, etc.) and/or to improve traceability of experiments or productions. Must be installed at our factory. It enables to choose between two printing modes:

- Simplified printing at the end of a cycle
- Extended printing during cycle



Download IT/MP
technical data sheet

External dot matrix printer

ITS-MP

Allows quick printing of the most relevant results from each sterilization cycle, with a selectable printing cadence between 10 and 240 seconds: program number, cycle number, temperature, time, date and time of each sterilization, and error messages.

Recommended to identify the process each preparation has undergone and/or to improve the traceability of experiments or productions. It enables to choose 2 printing modes through the media preparator screen:

- Simplified printing at the end of a cycle
- Extended printing during cycle



Download ITS-MP
technical data sheet



Qualification

External probe adapter

CAP-MP

External adapter for continuous validation processes that provides access to an external probe ($\varnothing 3-5\text{mm}$). The port is located on the door of the media preparator.



Download CAP-MP technical data sheet

Validation and qualification sets

TP-VAL-MP, TP-VAL-MP-20, TP-VAL-MP-40/60 & TP-VAL-MP-80/100

Set of reader and temperature probes of specific length and diameter to perform the validation and qualification of media preparators. This setup enables independent temperature readings of the culture medium, separate from those recorded by the equipment's built-in temperature probes.



Download technical data sheet

Customization of accessories and tailored solutions

At the core of our value proposition lies our commitment to innovation and continuous improvement. Thanks to our in-house R&D department, we have the capacity to go beyond standard expectations, adapting to the specific demands of our customers and developing customized solutions that address unique challenges.

A testament to our ability to innovate and customize is the development of the MP-TURBO model. This device, a 100L media preparator, is specifically designed for applications requiring the processing of high-viscosity or lumpy media. Ideal

for working with aqueous solutions enriched with starch, oats or vegetable flours, this version of the media preparator stands out due to the incorporation of the ULTRA-STIRR accessory and a custom high-performance peristaltic pump. This combination not only ensures efficient and homogeneous mixing, but also enables high-speed dispensing of very viscous culture media, proving our ability to offer tailored solutions.

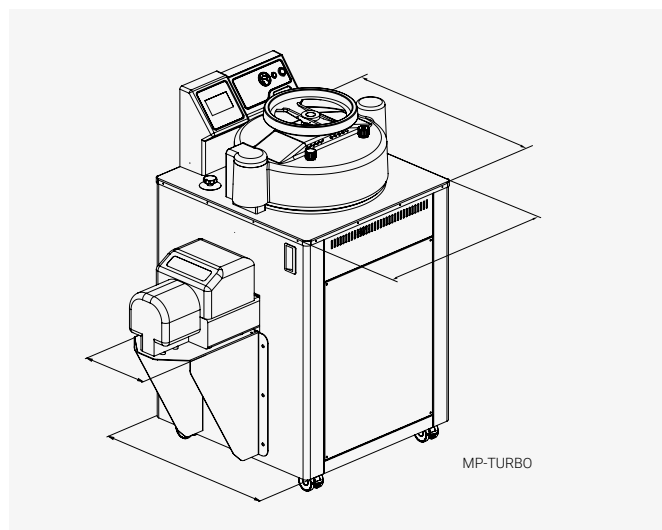



Attention: The availability and type of services described on this page will depend on the geographic location of the customer purchasing the equipment. Some services are offered free of charge after placing a media preparator order, while others may include additional fees. Moreover, some of these services may be provided directly by the manufacturer or by an authorized distributor trained and certified by RAYPA.

Customer support and 360° comprehensive consultancy

We are proud to offer our support and assistance to our customers, providing excellent individual consulting from the first commissioning offer to the performance of maintenance tasks or the shipment of spare parts. Among the services we offer are included:

Before the installation

- Commercial consultancy services regarding model, accessories and installation requirements.
- Technical consultancy services regarding application feasibility.
- Calibration certificates during the manufacturing process.

During the installation

- On-site or remote customer training sessions.
- Startup including the verification of the proper installation and a training session for users on the use and maintenance of the equipment.

After the installation

- Telephone and e-mail support for minor questions or problems.
- Comprehensive qualification services.
- Maintenance, calibration and repair services.
- Sale of original spare parts and components.
- Equipment loan or rental service.



Installation, validation, startup and maintenance



Installation

All the relevant information regarding the installation of AE-MP Series media preparators (electric requirements, water quality, model sizes, connections, maintenance, etc.) can be found in the installation guides available on our website.

The maximum environmental conditions in which the equipment is designed to operate are:

- **Room temperature:** 30°C.
- **Room humidity:** 75%.
- **Altitude:** 3.000 meters above sea level.

It may be possible to operate in settings with harsher environmental conditions after implementing some technical adjustments. Please contact our technical team for expert guidance.

Qualification

Our qualification services are available for new or used media preparators. These include a variety of documentation, accessories and services required to successfully qualify and validate a media preparator within the European Union and other international regulatory frameworks. The available services are:

- **Delivery of IQ/OQ documentation:** We provide installation qualification (IQ) and operational qualification (OQ) protocols for the validation of media preparators. It is a service designed for laboratories that require the media preparator's instructions and protocols to perform IQ/OQ qualification through third parties. It may also be of special interest to internal or external qualification companies.
- **IQ/OQ/PQ Qualification:** RAYPA offers a comprehensive service for installation qualification (IQ), operational qualification (OQ), and performance qualification (PQ) of media preparators. It is a service of special interest for laboratories working under stringent quality standards that require a comprehensive IQ/OQ/PQ qualification.



IQ: Installation qualification consists of determining whether the supplied unit complies with the manufacturer's specifications. It is the preliminary step to perform a satisfactory operational qualification. Maintenance, cleaning and calibration procedures, usually known as Standard Operating Procedures (SOPs), may be part of the IQ.

OQ: Operational qualification is an essential step during the development of a defined sterilization process. It consists of a series of tests that ensure the media preparator will operate within the quality limits or parameters set by the manufacturer. If any deviation occurs, engineers will determine and correct the cause of the problem.

PQ: Performance qualification is the third and final stage in the qualification process of a media preparator. This phase involves verifying and documenting that the media preparator operates consistently and repeatably in actual production. PQ tests, conducted over a specified period and under normal operating conditions, include real production simulations using the same materials, procedures, and controls as in daily production. If any deviations occur, engineers will determine and correct the cause of the problem.

Guided startup

As part of RAYPA after-sales services, our technical team (or authorized distributor) provides *in situ* guidance and training on equipment operation, program configuration, recommended maintenance and verification of proper equipment installation.

For clients in locations where *in situ* startup is not possible, we offer the option of conducting it remotely. We recommend the startup to all operators and managers who are in charge of editing or working with the programs of the media preparator. We also conduct more advanced sessions for experienced professionals who are interested in more complex features of program editing or managing the quality of the data generated.

Contents of an on-site guided startup

The on-site startup has an approximate duration of 4 hours and includes:

- ✓ Verification of correct installation.
- ✓ Verification of proper functioning + conducting a test cycle.
- ✓ Training session covering the following topics:

- Operation of the media preparator
- Proper use of the media preparator.
- Setting up a program.
- Dispensing setup.
- Common errors and their solutions.
- Precautionary measures to consider.
- Cleaning and maintenance training.
- How to communicate with technical support.
- Follow-up procedures.



[Download INSMP data sheet](#)



Contents of a remote guided startup

The remote startup has an approximate duration of 3 hours and includes:

- ✓ Verification of correct installation.
- ✓ Verification of proper functioning.
- ✓ Training session covering the following topics:

- Operation of the media preparator.
- Proper use of the media preparator.
- Setting up a program.
- Dispensing setup.
- Common errors and their solutions.
- Precautionary measures to consider.
- Cleaning and maintenance training.
- How to communicate with technical support.
- Follow-up procedures.



[Download INSMP-REM data sheet](#)



Preventive maintenance

At RAYPA we believe that media preparators should be easy to use, repair and maintain. To maximize uptime and keep the equipment in excellent condition, we offer after-sales services that include remote guidance for recommended maintenance, *in situ* execution of preventive maintenance along with equipment calibration, and annual plans covering maintenance, calibration, and spare parts supply.



Standard maintenance



Daily

Cleaning: gasket and external surfaces.
P1 CLEANING program.



Weekly

Cleaning: inner vessel, chamber and accessories.



Annually

Replacement: bacteriological filter.
Annual revision: technical inspection.

A more detailed explanation of the recommended maintenance can be found in the equipment manual and in the installation guide.



Stock of emergency components

Media preparators, like any other equipment, require preventive maintenance and occasional repairs with regular use. For customers who produce large quantities of culture media and cannot afford any equipment downtime, we recommend purchasing an emergency stock of components. The exact list of components will depend on the media preparator model and the purchased accessories, and will include spare parts that are subject to wear and components that are critical to the equipment's operation.

To receive a quote of this list of components, please contact our technical service at <https://www.raypa.com/en/technical-support-and-autoclave-spare-parts/>

Maintenance contract

As a part of RAYPA after-sales services, customers can benefit of special conditions by contracting an annual maintenance plan. The benefits include discounts on an annually scheduled *in situ* autoclave technical inspection, priority assistance and discounts on spare parts and travel expenses. The annually scheduled media preparator technical inspection includes the verification and validation of 20 control points (mechanical and electric safety elements), the calibration of temperature probes and the cleaning of the sterilization chamber. The review also includes a report of the tasks performed and recommendations of spare parts replacements if a component is detected not to be in optimum conditions. If the customer accepts this recommendation, the part will be repaired immediately using either the customer's own stock or that of our technical service.

To receive a quote of our maintenance contract, please contact our technical service at <https://www.raypa.com/en/technical-support-and-autoclave-spare-parts/>

After-sales services

We have a qualified technical service with global reach. Our technical service network has extensive industry experience and regularly participates in factory training sessions to ensure an excellent level of knowledge of our products. Additionally, we strive to ensure that our in-house technical service meets the highest standards of quality and efficiency in our extensive range of specialized services:

- **Professional consulting services:** we offer personalized advice to our clients from the initial start-up offer to the performance of maintenance tasks or the delivery of spare parts. We also offer on-site or remote training sessions for clients.
- **Guided startup:** as part of the services offered by RAYPA, we provide new customers with a guided startup, which can be either on-site or remote. This service includes a training session on equipment operation, program configuration, equipment cleaning, suggested maintenance, and troubleshooting. We also confirm—or assist the client in verifying—that the equipment and its accessories are correctly installed and functioning properly.
- **Maintenance plans:** we offer the flexibility to allow our clients to choose standard preventive maintenance contracts, or collaborate with them to design the support that best fits their needs.
- **Supply of original spare parts and components:** we have a warehouse and staff specifically dedicated to the supply of original spare parts and components for urgent shipments to any region of the world. We respond quickly and have stock of all references.



Technical data

Specifications

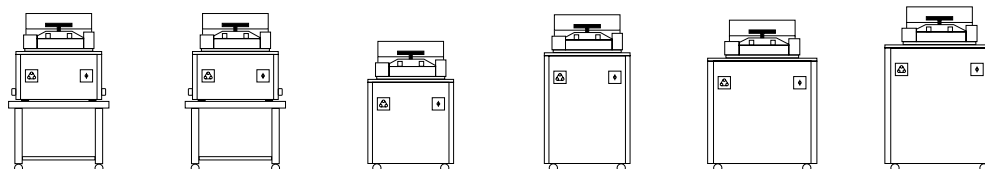

References	AE-20-MP-10L	AE-20-MP	AE-40-MP	AE-60-MP	AE-80-MP	AE-100-MP
Maximum capacity for preparing culture media L	8	18	36	54	72	90
Minimum capacity for preparing culture media* (by F ₀ or by time) L	2 or 5	2 or 10	5 or 20	10 or 30	20 or 50	20 or 70
Duration of heating phase from 25 to 121°C with max. volume min	60 - 65	70 - 75	40 - 80	55 - 80	30 - 60	35 - 80
Duration of cooling phase from 121 to 60°C with max. volume min	10 - 15	15 - 20	15 - 20	15 - 20	20 - 25	20 - 25
Total cycle duration min	85 - 100	100 - 115	70 - 120	85 - 120	65 - 105	70 - 125
External dimensions L x D x H mm	689 x 815 x 735	689 x 815 x 735	615 x 815 x 1100	615 x 815 x 1320	755 x 935 x 1285	755 x 935 x 1385
Inner vessel dimensions Ø x H mm	210 x 236	330 x 236	330 x 461	330 x 696	420 x 594	420 x 734
Net weight Kg	125	128	135	155	244	265
Available power options** kW	3	3	6 or 12	9 or 15	15, 20 or 30	15, 20 or 30
Standard voltage** V	230	230	400	400	400	400
Frequency Hz	50/60	50/60	50/60	50/60	50/60	50/60
Compliance with European Union regulations, including CE marking and PED	✓	✓	✓	✓	✓	✓

*The minimum volume capacity will be much lower if the sterilization is performed by F₀ instead of by time at 121°C. Refer to page 14 of this document for more information on this point.
 **Other voltages and electrical configurations available on request. Special versions with increased heating capacity may operate with other voltages. Contact our technical service for more information.
 ✓: Included





Safety

Our standard media preparators are equipped with a set of advanced safety systems that ensure both operator protection and process integrity. These systems are designed to prevent accidents, minimize operational risks, and guarantee a safe and efficient working environment throughout all process stages. The main systems they equip are:

- Safety valve.
- Safety thermostat with manual reset for electric heating elements.
- Pneumatic door locking system while positive pressure exists inside the sterilization chamber.
- Open door sensor.
- Thermally insulated door.
- Water level detector.
- Bacteriological filter for air inlet.
- Several visual and acoustic safety and warning alarms.

Certifications

All our standard media preparators are designed to comply with the strictest international directives and standards, including the following regulations:

- **EN-61010-1** Safety requirements for electrical equipment for measurement, control and laboratory use. Part 1: General requirements.
- **EN-61010-2-040** Part 2-040: Requirements for laboratory autoclaves.
- **EN-61326** Electrical equipment for measurement, control and laboratory use. EMC requirements.
- **AD 2000 Merkblatt** Pressure vessels.
- **2014/35/UE** Low voltage.
- **2014/30/UE** Electromagnetic compatibility.
- **2014/68/UE** Pressure equipment.
- **Specific UL/CSA electrical design certification** available upon request.



General features

Adjustable parameters	Sterilization temperature	50 - 125 °C
	Dispensing temperature	30 - 100 °C
	Sterilization time	1 - 250 min
	Pressure support	Up to 2,2Barg
Heating system	Powerful heating elements	
Dispensing system	Integrated single peristaltic pump. Second integrated peristaltic pump, external dosing station, or automatic culture medium dispensing system, all optional	
Stirring system	Removable magnetic stirrer with dual paddles, controlled by an independent potentiometer on the control panel, with a speed range of 50-200 rpm	
Sterilization control system	Completely automatic microprocessor control using a PT-100 flexible probe and chamber temperature probe. Control of the sterilization cycle by F_0 value or by chamber temperature	
Monitoring of sterilization parameters	Self-control of obtained values (T° , P & t) vs programmed values. Cycle is automatically interrupted if obtained values differ from programmed values	
Pressure control	Pressure gauge on control panel, digital display on screen, registry on software and ticket printer	
Building materials	Sterilization chamber, inner vessel and door made of AISI 316L. External housing made of AISI 304. Silicone door gasket	
Mobility	4 casters with brakes. Benchtop models are equipped with feet	
Door opening	Horizontal swiveling door with locking system	
Number of programs	50 programs adjustable by time and temperature. The temperature control can be programmed by F_0 or by chamber temperature. It is also possible to keep the temperature constant at the end of the cycle and to adjust the dispensing temperature, the stirring speed and the pressure support during the dispensing phase	
Programmable auto-start	Unlimited range	
Display	5" color TFT-LCD touchscreen display	
External data transfer	Optional external printer, integrated printer or specific software with Ethernet and USB connections	
Water management	Independent inner vessel manually filled with purified water. The sterilization chamber is manually filled with purified water, with the option of upgrading it by implementing a fully automatic clean water feed directly from the water supply network. The cooling coil requires a connection to a decalcified water network	
Drainage system	A drain connection is required for the cooling coil outlet and the sterilization chamber drain outlet	



Annexes

Electrical connection

Standard

The following table shows the plug configuration according to international IEC and SCHUKO standards. For customers requiring other plugs and other electrical configurations, please contact our technical team.

MODELS	FREQUENCY	POWER	AMPERES / PHASE	TENSION	CONNECTION
AE-20-MP-10L	50/60 Hz	3000 W	13 A	230 (1P+N+PE) V	16 A ①
AE-20-MP-10L-115V	50/60 Hz	3000 W	26 A	120 (1P+N+PE) V	32 A ④
AE-20-MP	50/60 Hz	3000 W	13 A	230 (1P+N+PE) V	16 A ①
AE-20-MP-115V	50/60 Hz	3000 W	26 A	120 (1P+N+PE) V	32 A ④
AE-40-MP	50/60 Hz	6000 W	9 A	400 (3P+N+PE) V	16 A ②
AE-40-MP-12K	50/60 Hz	12000 W	18 A	400 (3P+N+PE) V	32 A ③
AE-40-MP-220T	50/60 Hz	6000 W	15 A	230 (3P+PE) V	16 A ⑤
AE-40-MP-220M	50/60 Hz	6000 W	26 A	230 (1P+N+PE) V	32 A ④
AE-40-MP-12K-220T	50/60 Hz	12000 W	30 A	230 (3P+PE) V	32 A ⑥
AE-60-MP	50/60 Hz	9000 W	13 A	400 (3P+N+PE) V	16 A ②
AE-60-MP-15K	50/60 Hz	15000 W	22 A	400 (3P+N+PE) V	32 A ③
AE-60-MP-220T	50/60 Hz	9000 W	23 A	230 (3P+PE) V	32 A ⑥
AE-60-MP-15K-220T	50/60 Hz	15000 W	38 A	230 (3P+PE) V	63 A ⑧
AE-80-MP	50/60 Hz	15000 W	22 A	400 (3P+N+PE) V	32 A ③
AE-80-MP-20K	50/60 Hz	20000 W	29 A	400 (3P+N+PE) V	32 A ③
AE-80-MP-30K	50/60 Hz	30000 W	43 A	400 (3P+N+PE) V	63 A ⑦
AE-80-MP-220T	50/60 Hz	15000 W	38 A	230 (3P+PE) V	63 A ⑧
AE-80-MP-20K-220T	50/60 Hz	20000 W	51 A	230 (3P+PE) V	63 A ⑧
AE-100-MP	50/60 Hz	15000 W	22 A	400 (3P+N+PE) V	32 A ③
AE-100-MP-20K	50/60 Hz	20000 W	29 A	400 (3P+N+PE) V	32 A ③
AE-100-MP-30K	50/60 Hz	30000 W	43 A	400 (3P+N+PE) V	63 A ⑦
AE-100-MP-220T	50/60 Hz	15000 W	38 A	230 (3P+PE) V	63 A ⑧
AE-100-MP-20K-220T	50/60 Hz	20000 W	51 A	230 (3P+PE) V	63 A ⑧

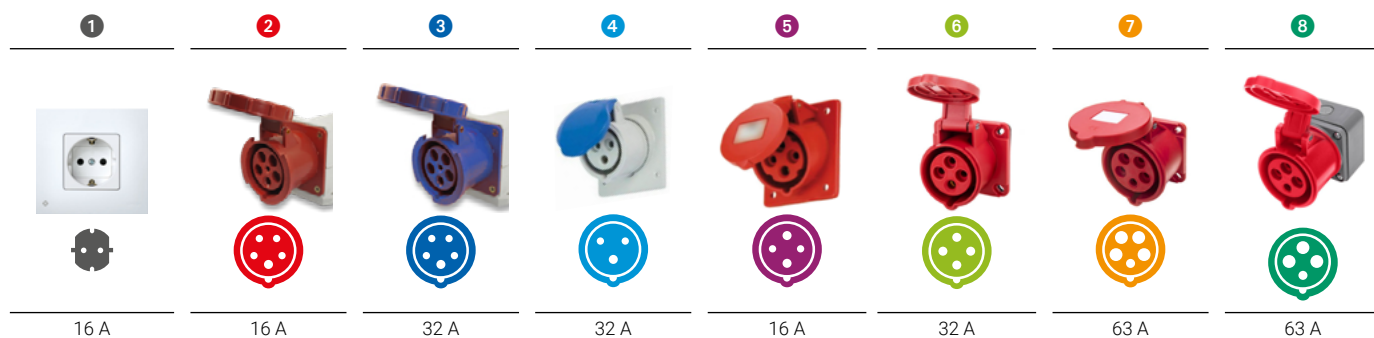



North America

The following table shows the plug configuration according to the NEMA standard for the United States and other countries. For customers requiring other plugs and other electrical configurations, please contact our technical team.

Attention: The following table lists standard electrical configuration versions. The voltage can be modified to suit other configurations if required. Additionally, the provided NEMA plug can also be customized if needed.

MODELS	FREQUENCY	POWER	AMPERES / PHASE	TENSION	CONNECTION
AE-20-MP-10L-115V-US	50/60 Hz	3000 W	26 A	120 (1P+N+PE) V	NEMA 5-30P 1
AE-20-MP-115V-US	50/60 Hz	3000 W	26 A	120 (1P+N+PE) V	NEMA 5-30P 1
AE-40-MP-220T-US	50/60 Hz	6000 W	15 A	230 (3P+PE) V	NEMA L15-20P 2
AE-40-MP-12K-220T-US	50/60 Hz	12000 W	30 A	230 (3P+PE) V	NEMA 15-50P 4
AE-60-MP-220T-US	50/60 Hz	9000 W	23 A	230 (3P+PE) V	NEMA L15-30P 3
AE-60-MP-15K-220T-US	50/60 Hz	15000 W	38 A	230 (3P+PE) V	NEMA 15-50P 4
AE-80-MP-220T-US	50/60 Hz	15000 W	38 A	230 (3P+PE) V	NEMA 15-50P 4
AE-80-MP-20K-220T-US	50/60 Hz	20000 W	51 A	230 (3P+PE) V	NEMA 15-60P 5
AE-100-MP-220T-US	50/60 Hz	15000 W	38 A	230 (3P+PE) V	NEMA 15-50P 4
AE-100-MP-20K-220T-US	50/60 Hz	20000 W	51 A	230 (3P+PE) V	NEMA 15-60P 5

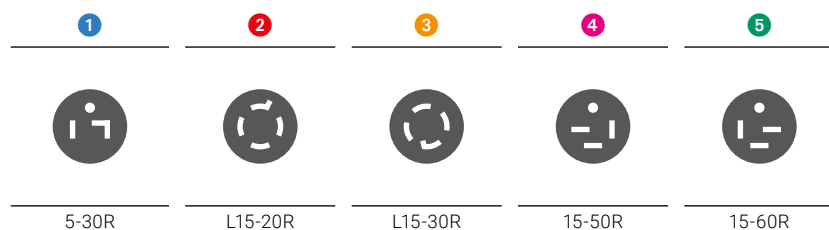



Technical drawings

AE-20-MP-10L + TABLE-MP / AE-20-MP + TABLE-MP

MODELS	L LENGTH with closed door	L1 LENGTH with maximum door opening	D DEPTH	H HEIGHT	HL LOADING HEIGHT	HD STERILIZATION CHAMBER DRAIN HEIGHT	HE COOLING WATER OUTLET HEIGHT
AE-20-MP-10L + TABLE-MP	700 mm	1138 mm	815 mm	1380 mm	1055 mm	100 mm	330 mm
AE-20-MP + TABLE-MP	700 mm	1138 mm	815 mm	1380 mm	1055 mm	100 mm	330 mm

CONNECTIONS

1	Safety thermostat	8	Sterilization chamber drain outlet
2	Safety valve outlet	9	Steam purge, autocleaning and dosage outlet
3	Optional purge outlet	10	USB port
4	Dosage pedal port	11	Ethernet port
5	Cooling water outlet	12	Power cable
6	Cooling water inlet	13	Drain tap
7	Sterilization water inlet		

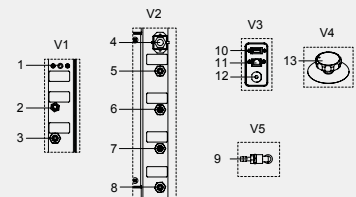
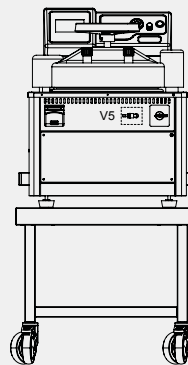
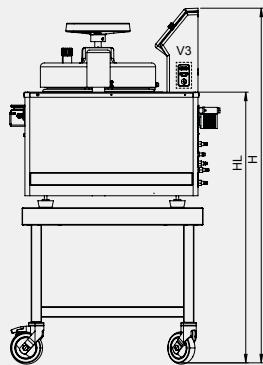
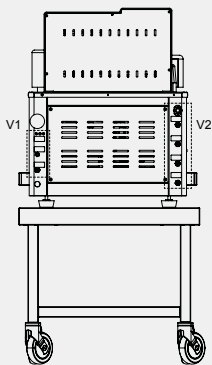
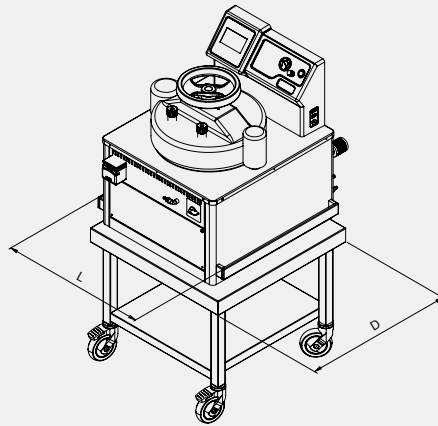
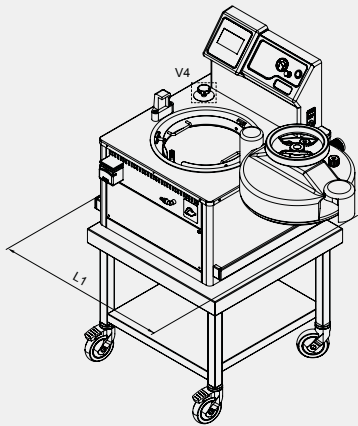



AE-40-MP / AE-60-MP / AE-80-MP / AE-100-MP

MODELS	L LENGTH with closed door	L1 LENGTH with maximum door opening	D DEPTH	H HEIGHT	HL LOADING HEIGHT	HD STERILIZATION CHAMBER DRAIN OUTLET	HE COOLING WATER OUTLET
AE-40-MP	615 mm	1100 mm	815 mm	1100 mm	770 mm	120 mm	350 mm
AE-60-MP	615 mm	1100 mm	815 mm	1315 mm	990 mm	140 mm	365 mm
AE-80-MP	755 mm	1380 mm	935 mm	1230 mm	910 mm	145 mm	365 mm
AE-100-MP	755 mm	1380 mm	935 mm	1375 mm	1050 mm	145 mm	365 mm

CONNECTIONS

- | | | | |
|---|-----------------------|----|---|
| 1 | Safety thermostat | 8 | Sterilization water inlet |
| 2 | Safety valve outlet | 9 | Sterilization chamber drain outlet |
| 3 | Optional purge outlet | 10 | Steam purge, autocleaning and dosage outlet |
| 4 | Power cable | 11 | USB port |
| 5 | Dosage pedal port | 12 | Ethernet port |
| 6 | Cooling water outlet | 13 | Drain tap |
| 7 | Cooling water inlet | | |

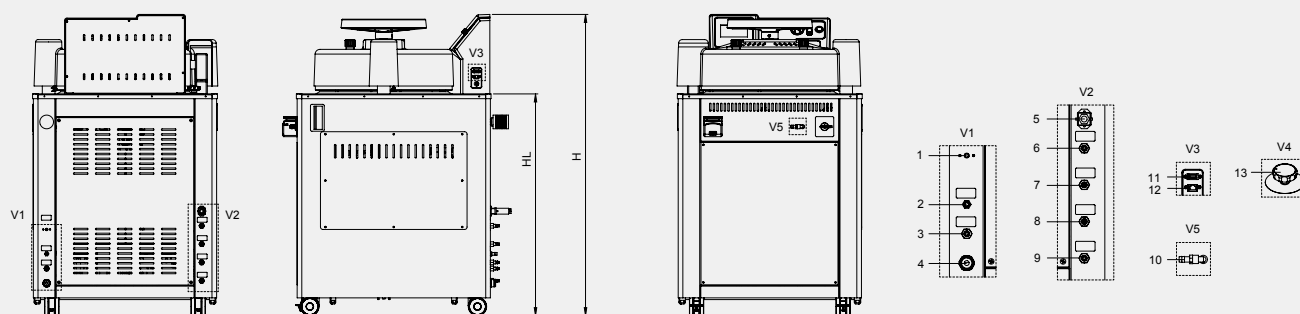
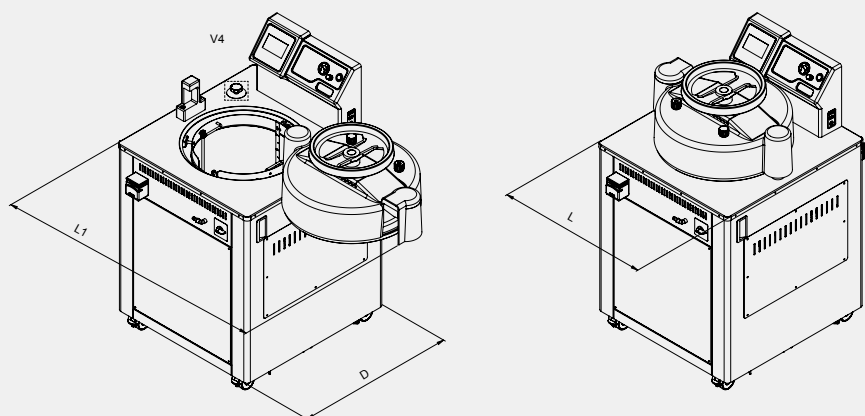



**NEW
VIDEO!**

Expert and
standard media
preparators



RAYPA

www.mediapreparators.com

www.raypa.com

Avinguda del Vallès, 322
08227 Terrassa (Barcelona) Spain